



INA103

Low Noise, Low Distortion INSTRUMENTATION AMPLIFIER

FEATURES

- **LOW NOISE:** $1\text{nV}/\sqrt{\text{Hz}}$
- **LOW THD+N:** 0.0009% at 1kHz, $G = 100$
- **HIGH GBW:** 100MHz at $G = 1000$
- **WIDE SUPPLY RANGE:** $\pm 9\text{V}$ to $\pm 25\text{V}$
- **HIGH CMRR:** $>110\text{dB}$
- **BUILT-IN GAIN SETTING RESISTORS:**
 $G = 1, 100$
- **UPGRADES AD625**

APPLICATIONS

- **HIGH QUALITY MICROPHONE PREAMPS (REPLACES TRANSFORMERS)**
- **MOVING-COIL PREAMPLIFIERS**
- **DIFFERENTIAL RECEIVERS**
- **AMPLIFICATION OF SIGNALS FROM:**
Strain Gages (Weigh Scale Applications)
Thermocouples
Bridge Transducers

DESCRIPTION

The INA103 is a very low noise, low distortion monolithic instrumentation amplifier. Its current-feedback circuitry achieves very wide bandwidth and excellent dynamic response. It is ideal for low-level audio signals such as balanced low-impedance microphones. The INA103 provides near-theoretical limit noise performance for 200Ω source impedances. Many industrial applications also benefit from its low noise and wide bandwidth.

Unique distortion cancellation circuitry reduces distortion to extremely low levels, even in high gain. Its balanced input, low noise and low distortion provide superior performance compared to transformer-coupled microphone amplifiers used in professional audio equipment.

The INA103's wide supply voltage (± 9 to $\pm 25\text{V}$) and high output current drive allow its use in high-level audio stages as well. A copper lead frame in the plastic DIP assures excellent thermal performance.

The INA103 is available in 16-pin plastic DIP, 16-pin ceramic DIP and SOL-16 surface-mount packages. Commercial and industrial temperature range models are available.

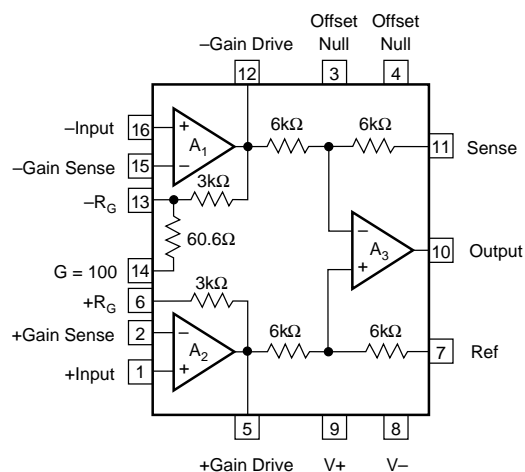

International Airport Industrial Park • Mailing Address: PO Box 11400 • Tucson, AZ 85734 • Street Address: 6730 S. Tucson Blvd. • Tucson, AZ 85706
Tel: (520) 746-1111 • Twx: 910-952-1111 • Cable: BBRCORP • Telex: 066-6491 • FAX: (520) 889-1510 • Immediate Product Info: (800) 548-6132

SPECIFICATIONS

ELECTRICAL

All specifications at $T_A = +25^\circ\text{C}$, $V_S = \pm 15\text{V}$ and $R_L = 2\text{k}\Omega$, unless otherwise noted.

PARAMETER	CONDITIONS	INA103AG			INA103BG			INA103KP, KU			UNITS
		MIN	TYP	MAX	MIN	TYP	MAX	MIN	TYP	MAX	
GAIN											
Range of Gain		1		1000	*		*	*		*	V/V
Gain Equation ⁽¹⁾		$G = 1 + 6\text{k}\Omega/R_G$				*			*	*	V/V
Gain Error, DC $G = 1$	$\pm 10\text{V}$ Output		0.005	0.05		0.003	0.01		*	*	%
Gain Error, DC $G = 100$	$\pm 10\text{V}$ Output		0.05	0.25		0.04	0.1		0.07	*	%
Gain Temp. Co. $G = 1$	$\pm 10\text{V}$ Output		0.5			0.1			*	*	%
Gain Temp. Co. $G = 100$	$\pm 10\text{V}$ Output		10			*			*	*	ppm/ $^\circ\text{C}$
Gain Temp. Co. $G = 100$	$\pm 10\text{V}$ Output		25			*			*	*	ppm/ $^\circ\text{C}$
Nonlinearity, DC $G = 1$	$\pm 10\text{V}$ Output		0.0003	0.01		0.0002	0.002		*	*	% of FS ⁽²⁾
Nonlinearity, DC $G = 100$	$\pm 10\text{V}$ Output		0.0006	0.01		0.0006	0.004		*	*	% of FS
OUTPUT											
Voltage, $R_L = 600\Omega$	$T_A = T_{\text{MIN}}$ to T_{MAX}	± 11.5	± 12		*	*		*	*		V
Voltage, $R_L = 600\Omega$	$V_S = \pm 25$, $T_A = 25^\circ\text{C}$	± 20	± 21		*	*		*	*		V
Current	$T_A = T_{\text{MIN}}$ to T_{MAX}	± 40			*	*		*	*		mA
Short Circuit Current			± 70			*			*		mA
Capacitive Load Stability			10			*			*		nF
INPUT OFFSET VOLTAGE											
Initial Offset RTI ⁽³⁾			(20 + 700/G)	(100 + 5000/G)		(20 + 320/G)	(50 + 2000/G)		(30 + 1200/G)		μV
(KU Grade)										(250 + 5000/G)	μV
vs Temp $G = 1$ to 1000	$T_A = T_{\text{MIN}}$ to T_{MAX}		1 + 20/G			0.75 + 10/G			1 + 20/G		$\mu\text{V}/^\circ\text{C}$
vs Supply	$T_A = T_{\text{MIN}}$ to T_{MAX}		1	2		*	*		*	*	$\mu\text{V}/^\circ\text{C}$
	$\pm 9\text{V}$ to $\pm 25\text{V}$		0.2 + 8/G	4 + 60/G		*	2 + 30/G		*	*	$\mu\text{V}/\text{V}$
INPUT BIAS CURRENT											
Initial Bias Current	$T_A = T_{\text{MIN}}$ to T_{MAX}		2.5	12		*	8		*	*	μA
vs Temp	$T_A = T_{\text{MIN}}$ to T_{MAX}		15			*	40 ⁽⁴⁾		*	*	nA/ $^\circ\text{C}$
Initial Offset Current	$T_A = T_{\text{MIN}}$ to T_{MAX}		0.04	1		0.03	0.5		*	*	μA
vs Temp	$T_A = T_{\text{MIN}}$ to T_{MAX}		0.5			*	2.5 ⁽⁴⁾		*	*	nA/ $^\circ\text{C}$
INPUT IMPEDANCE											
Differential Mode			60 2			*			*	*	M Ω pF
Common-Mode			60 5			*			*	*	M Ω pF
INPUT VOLTAGE RANGE											
Common-Mode Range ⁽⁵⁾		± 11	± 12		*	*		*	*		V
CMR											
$G = 1$	DC to 60Hz	72	86		80	91		*	*		dB
$G = 100$	DC to 60Hz	100	125		110	129		*	*		dB
INPUT NOISE											
Voltage ⁽⁶⁾	$R_S = 0\Omega$										
10Hz			2			*			*	*	nV/ $\sqrt{\text{Hz}}$
100Hz			1.2			*			*	*	nV/ $\sqrt{\text{Hz}}$
1kHz			1			*	1.4 ⁽⁴⁾		*	*	nV/ $\sqrt{\text{Hz}}$
Current, 1kHz			2			*			*	*	pA/ $\sqrt{\text{Hz}}$
OUTPUT NOISE											
Voltage	1kHz		65			*			*	*	nV/ $\sqrt{\text{Hz}}$
A Weighted, 20Hz-20kHz	20Hz-20kHz		-100			*			*	*	dBu
DYNAMIC RESPONSE											
-3dB Bandwidth: $G = 1$	Small Signal		6			*			*	*	MHz
$G = 100$	Small Signal		800			*			*	*	kHz
Full Power Bandwidth	$G = 1$					*			*	*	kHz
Slew Rate	$V_{\text{OUT}} = \pm 10\text{V}$, $R_L = 600\Omega$		240			*			*	*	V/ μs
THD + Noise	$G = 1$ to 500		15			*			*	*	%
Settling Time 0.1%	$G = 100$, $f = 1\text{kHz}$		0.0009			*			*	*	%
Settling Time 0.1%	$V_O = 20\text{V}$ Step		1.7			*			*	*	μs
$G = 100$	$V_O = 20\text{V}$ Step		1.5			*			*	*	μs
Settling Time 0.01%	$V_O = 20\text{V}$ Step		2			*			*	*	μs
$G = 100$	$V_O = 20\text{V}$ Step		3.5			*			*	*	μs
Overload Recovery ⁽⁷⁾	50% Overdrive		1			*			*	*	μs

*Same specification as INA103AG.

NOTES: (1) Gains other than 1 and 100 can be set by adding an external resistor, R_G between pins 2 and 15. Gain accuracy is a function of R_G . (2) FS = Full Scale. (3) Adjustable to zero. (4) Guaranteed by design. (5) $V_O = 0\text{V}$, see Typical Curves for V_{CM} vs V_O . (6) $V_{\text{NOISE RTI}} = \sqrt{V_{\text{N INPUT}}^2 + (V_{\text{N OUTPUT}}/\text{Gain})^2 + 4\text{KTR}_G}$. See Typical Curves. (7) Time required for output to return from saturation to linear operation following the removal of an input overdrive voltage.

SPECIFICATIONS (CONT)

ELECTRICAL

All specifications at $T_A = +25^\circ\text{C}$, $V_S = \pm 15\text{V}$ and $R_L = 2\text{k}\Omega$, unless otherwise noted.

PARAMETER	CONDITIONS	INA103AG			INA103BG			INA103KP, KU			UNITS
		MIN	TYP	MAX	MIN	TYP	MAX	MIN	TYP	MAX	
POWER SUPPLY	Rated Voltage		± 15			*	*		*	*	V
	Voltage Range	± 9		± 25	*	*	*	*	*	*	V
	Quiescent Current		9	12.5		*	*		*	*	mA
TEMPERATURE RANGE	Specification	-25		+85	*		*	0		+70	$^\circ\text{C}$
	Operation	-55		+125	*		*	-40		+85	$^\circ\text{C}$
	Storage	-65		+150	*		*	-40		+100	$^\circ\text{C}$
	Thermal Resistance, θ_{JA}		100			*	*		*		$^\circ\text{C}/\text{W}$

DICE INFORMATION

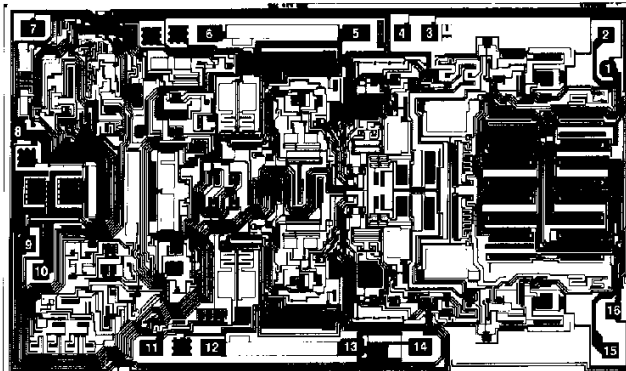

INA103 DIE TOPOGRAPHY

PAD	FUNCTION	PAD	FUNCTION
1	+Input	9	V+
2	+Gain Sense	10	Output
3	+Offset Null	11	Sense
4	-Offset Null	12	-Gain Drive
5	+Gain Drive	13	- R_G
6	+ R_G	14	G = 100
7	Ref	15	-Gain Sense
8	V-	16	-Input

Substrate Bias: Electrically connected to V- supply.

MECHANICAL INFORMATION

	MILS (0.001")	MILLIMETERS
Die Size	194 x 115 ± 5	4.93 x 2.92 ± 0.13
Die Thickness	20 ± 3	0.51 ± 0.08
Min. Pad Size	4 x 4	0.1 x 0.1
Backing	Chromium-Silver	

PACKAGE INFORMATION

MODEL	PACKAGE	PACKAGE DRAWING NUMBER ⁽¹⁾
INA103AG	Ceramic DIP	109
INA103BG	Ceramic DIP	109
INA103KP	Plastic DIP	180
INA103KU	SOL-16	211

NOTE: (1) For detailed drawing and dimension table, please see end of data sheet, or Appendix D of Burr-Brown IC Data Book.

ORDERING INFORMATION

MODEL	PACKAGE	TEMP RANGE
INA103AG	Ceramic DIP	-25 $^\circ\text{C}$ to +85 $^\circ\text{C}$
INA103BG	Ceramic DIP	-25 $^\circ\text{C}$ to +85 $^\circ\text{C}$
INA103KP	Plastic DIP	0 $^\circ\text{C}$ to +70 $^\circ\text{C}$
INA103KU	SOL-16	0 $^\circ\text{C}$ to +70 $^\circ\text{C}$

ELECTROSTATIC DISCHARGE SENSITIVITY

Any integrated circuit can be damaged by ESD. Burr-Brown recommends that all integrated circuits be handled with appropriate precautions. Failure to observe proper handling and installation procedures can cause damage.

ESD damage can range from subtle performance degradation to complete device failure. Precision integrated circuits may be more susceptible to damage because very small parametric changes could cause the device not to meet published specifications.

PIN CONFIGURATION

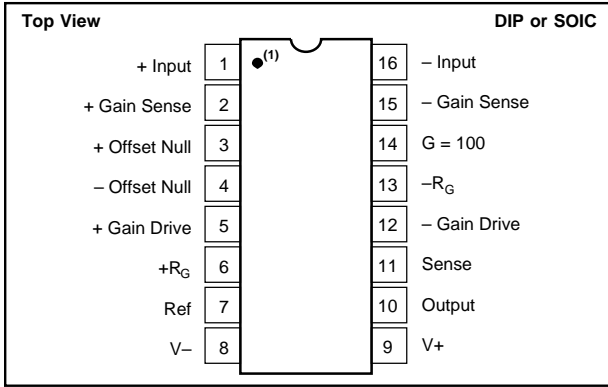

NOTE: (1) Pin 1 Marking—SOL-16 Package

ABSOLUTE MAXIMUM RATINGS

Power Supply Voltage	$\pm 25\text{V}$
Input Voltage Range, Continuous	$\pm V_S$
Operating Temperature Range:	
P, U Package	-40°C to $+85^\circ\text{C}$
G Package	-55°C to $+125^\circ\text{C}$
Storage Temperature Range:	
P, U Package	-40°C to $+100^\circ\text{C}$
G Package	-65°C to $+150^\circ\text{C}$
Junction Temperature:	
P, U Package	$+125^\circ\text{C}$
G Package	$+150^\circ\text{C}$
Lead Temperature (soldering, 10s)	$+300^\circ\text{C}$
Output Short Circuit to Common	Continuous

TYPICAL PERFORMANCE CURVES

At $T_A = +25^\circ\text{C}$, $V_S = \pm 15\text{V}$ unless otherwise noted.

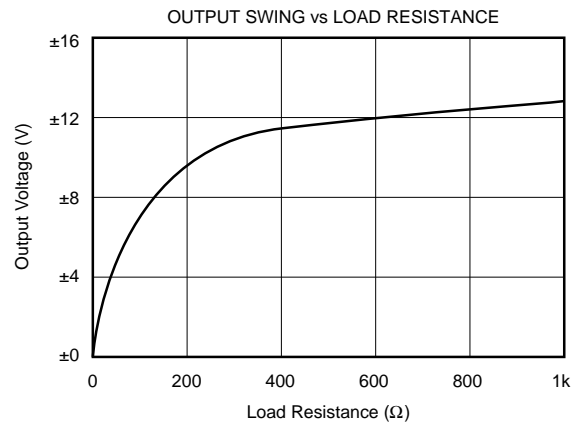
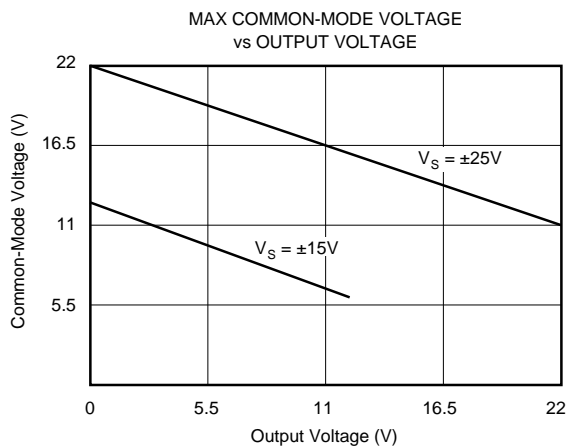
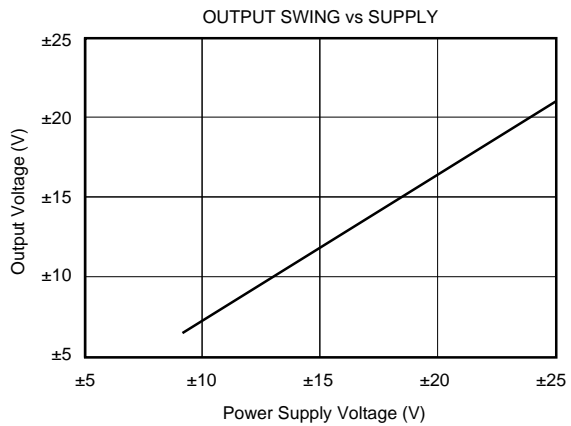
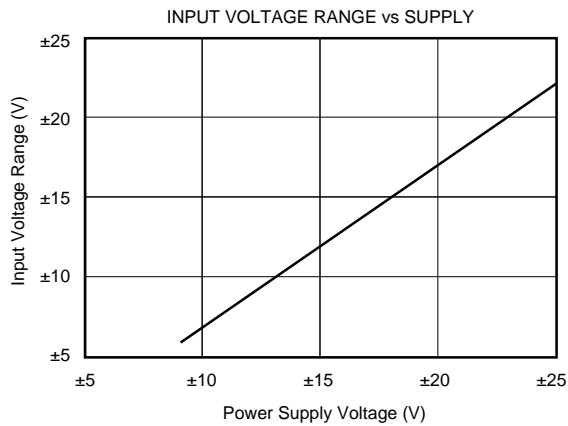

TYPICAL PERFORMANCE CURVES (CONT)

At $T_A = +25^\circ\text{C}$, $V_S = \pm 15\text{V}$ unless otherwise noted.

OFFSET VOLTAGE vs TIME FROM POWER UP
(G = 100)

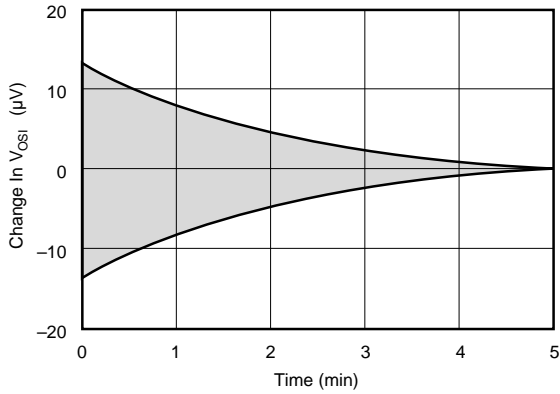

INPUT BIAS CURRENT vs SUPPLY

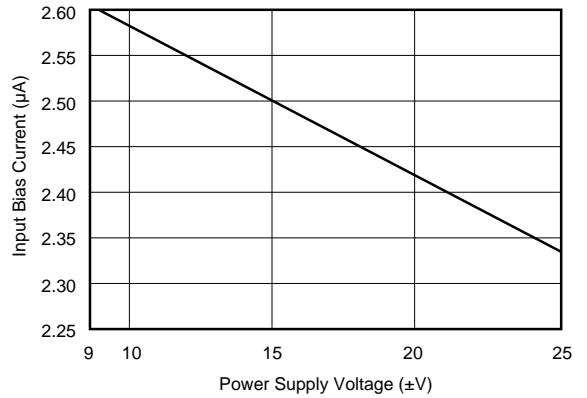

INPUT BIAS CURRENT vs TEMPERATURE

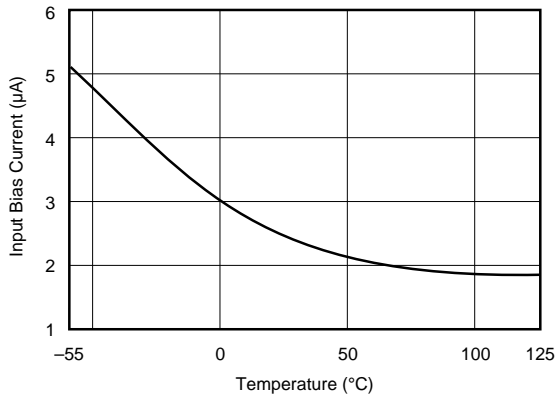

SMALL SIGNAL TRANSIENT RESPONSE
(G = 1)

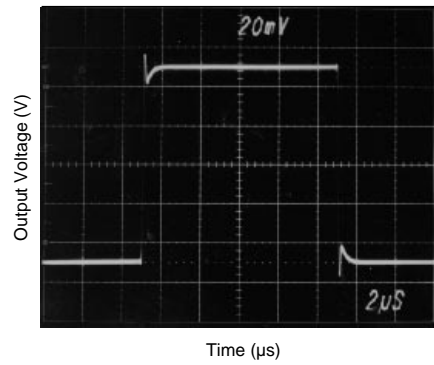

SMALL SIGNAL TRANSIENT RESPONSE
(G = 100)

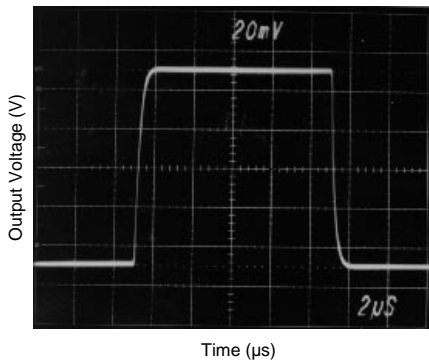

LARGE SIGNAL TRANSIENT RESPONSE
(G = 1)

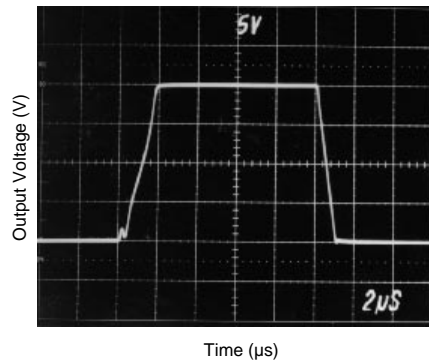

TYPICAL PERFORMANCE CURVES (CONT)

At $T_A = +25^\circ\text{C}$, $V_S = \pm 15\text{V}$ unless otherwise noted.

LARGE SIGNAL TRANSIENT RESPONSE
(G = 100)

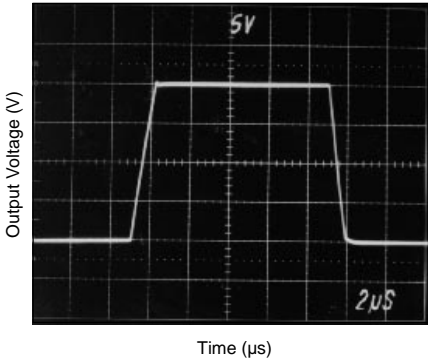

SETTLING TIME vs GAIN
(0.1%, 20V STEP)

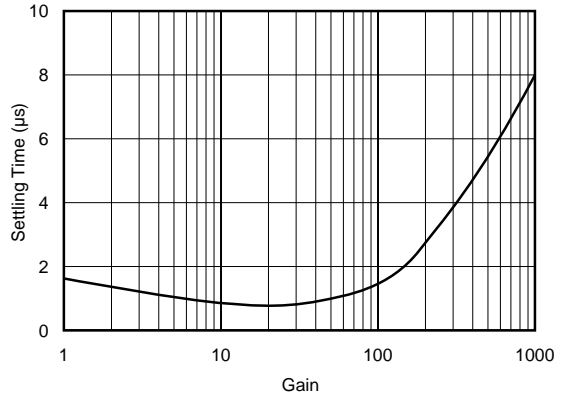

SETTLING TIME vs GAIN
(0.01%, 20V STEP)

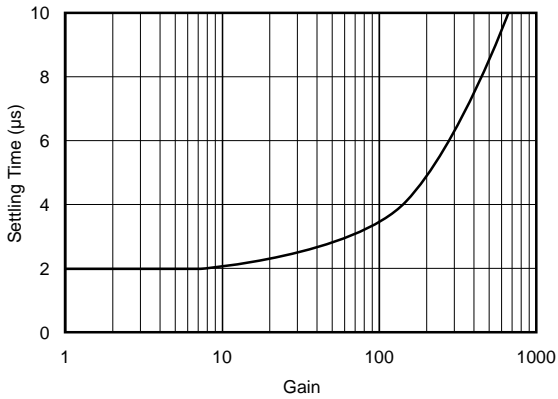

SMALL-SIGNAL FREQUENCY RESPONSE

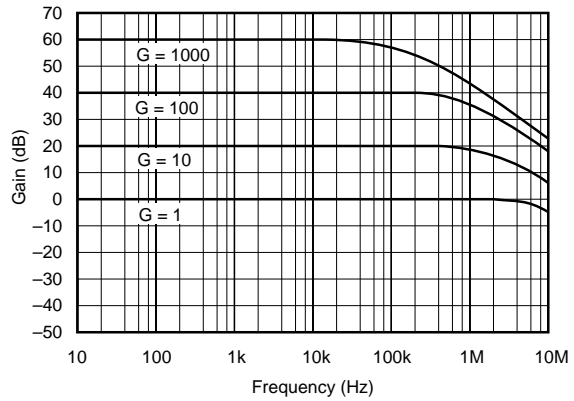

NOISE VOLTAGE (RTI) vs FREQUENCY

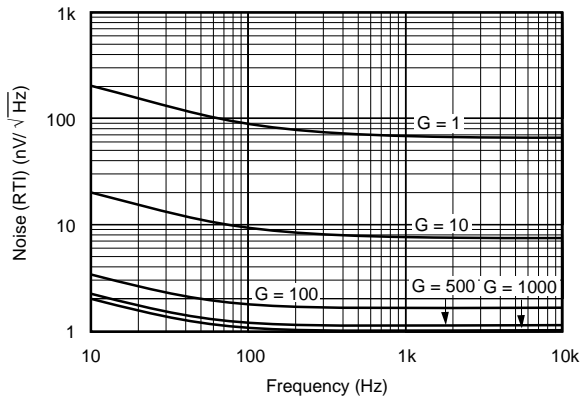

CMR vs FREQUENCY

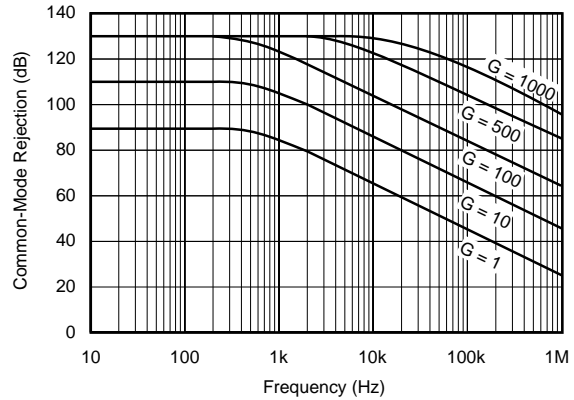

TYPICAL PERFORMANCE CURVES (CONT)

At $T_A = +25^\circ\text{C}$, $V_S = \pm 15\text{V}$ unless otherwise noted.

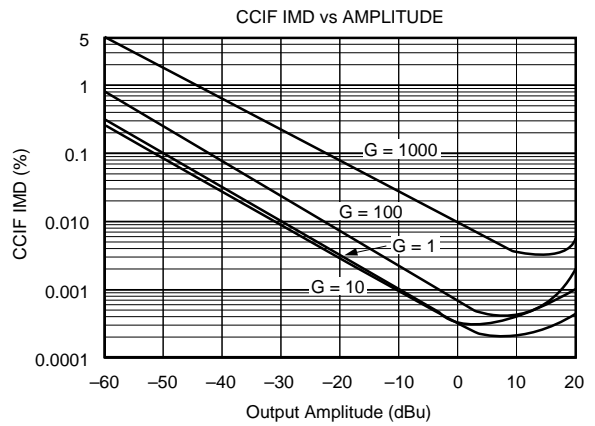
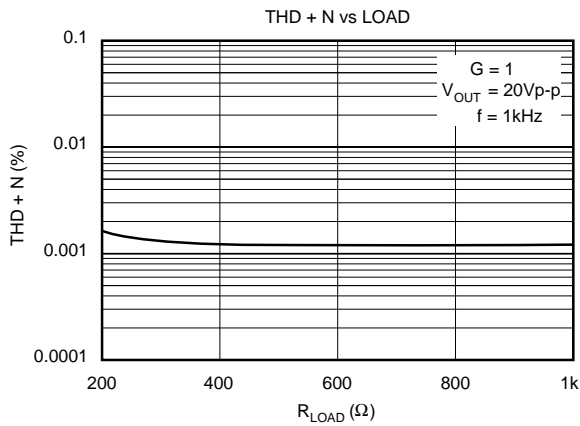
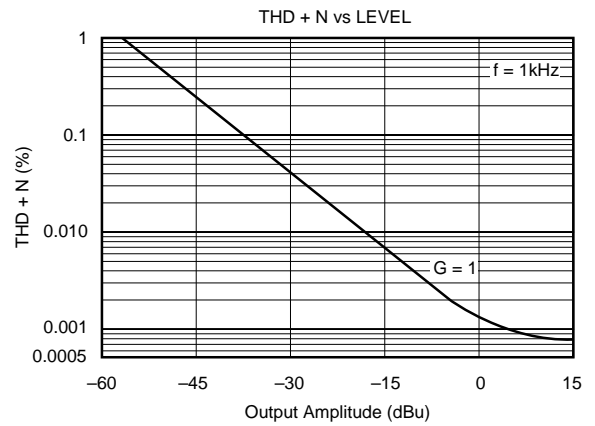
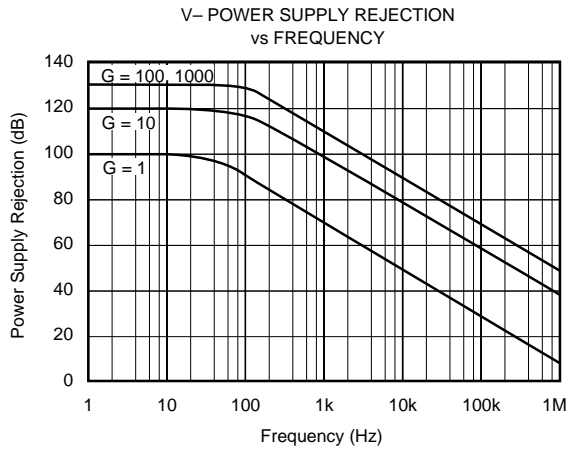
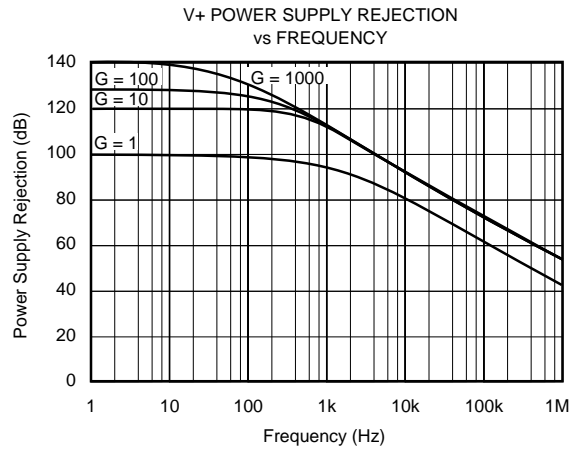
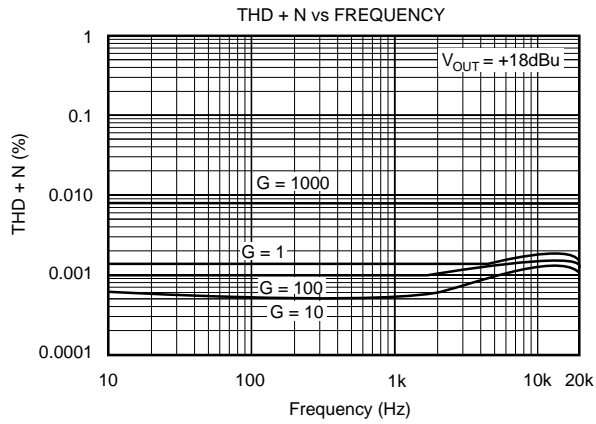

TYPICAL PERFORMANCE CURVES (CONT)

At $T_A = +25^\circ\text{C}$, $V_S = \pm 15\text{V}$ unless otherwise noted.

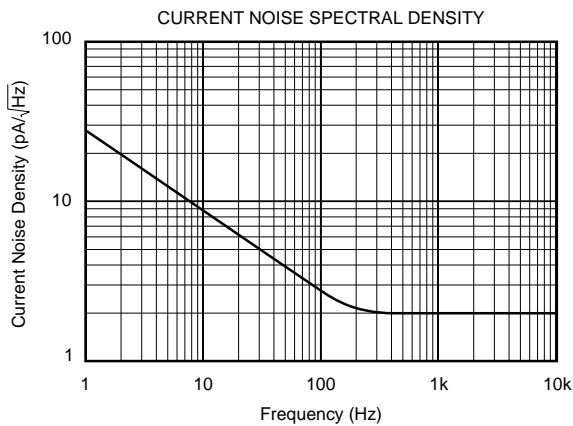
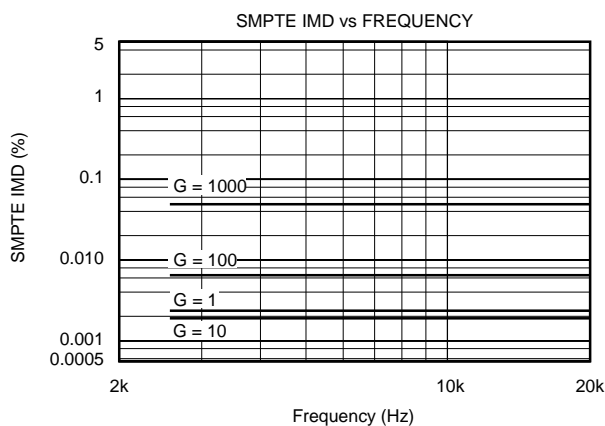
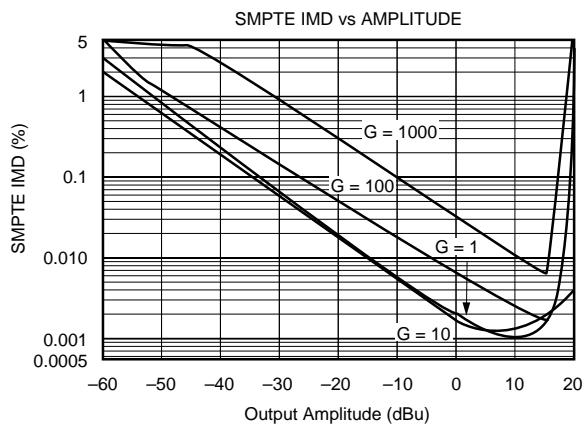
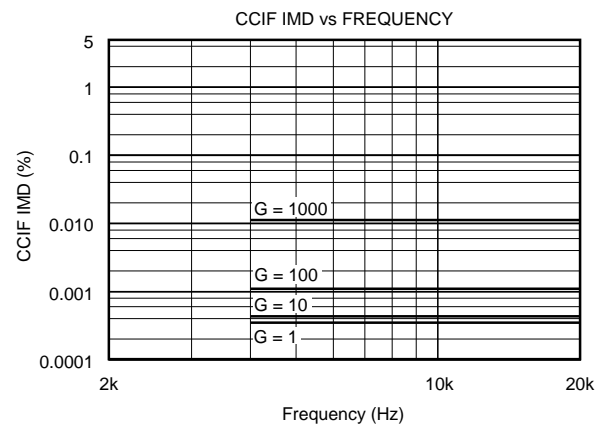

APPLICATIONS INFORMATION

Figure 1 shows the basic connections required for operation. Power supplies should be bypassed with $1\mu\text{F}$ tantalum capacitors near the device pins. The output Sense (pin 11) and output Reference (pin 7) should be low impedance connections. Resistance of a few ohms in series with these connections will degrade the common-mode rejection of the amplifier.

To avoid oscillations, make short, direct connection to the gain set resistor and gain sense connections. Avoid running output signals near these sensitive input nodes.

INPUT CONSIDERATIONS

Certain source impedances can cause the INA103 to oscillate. This depends on circuit layout and source or cable characteristics connected to the input. An input network consisting of a small inductor and resistor (Figure 2) can greatly reduce the tendency to oscillate. This is especially

useful if various input sources are connected to the INA103. Although not shown in other figures, this network can be used, if needed, with all applications shown.

GAIN SELECTION

Gains of 1 or 100V/V can be set without external resistors. For $G = 1\text{V/V}$ (unity gain) leave pin 14 open (no connection)—see Figure 4. For $G = 100\text{V/V}$, connect pin 14 to pin 6—see Figure 5.

Gain can also be accurately set with a single external resistor as shown in Figure 1. The two internal feedback resistors are laser-trimmed to $3\text{k}\Omega$ within approximately $\pm 0.1\%$. The temperature coefficient of these resistors is approximately $50\text{ppm}/^\circ\text{C}$. Gain using an external R_G resistor is—

$$G = 1 + \frac{6\text{k}\Omega}{R_G}$$

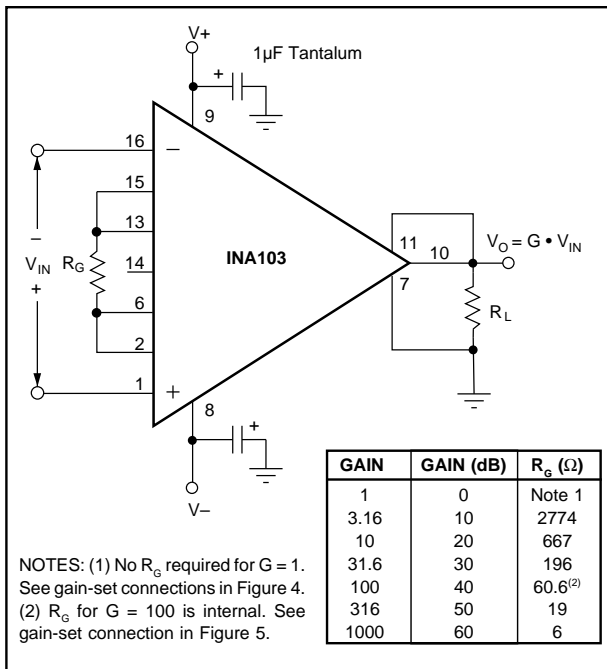

FIGURE 1. Basic Circuit Configuration.

Accuracy and TCR of the external R_G will also contribute to gain error and temperature drift. These effects can be directly inferred from the gain equation.

Connections available on A₁ and A₂ allow external resistors to be substituted for the internal 3kΩ feedback resistors. A precision resistor network can be used for very accurate and stable gains. To preserve the low noise of the INA103, the value of external feedback resistors should be kept low. Increasing the feedback resistors to 20kΩ would increase noise of the INA103 to approximately 1.5nV/√Hz. Due to the current-feedback input circuitry, bandwidth would also be reduced.

NOISE PERFORMANCE

The INA103 provides very low noise with low source impedance. Its 1nV/√Hz voltage noise delivers near theoretical noise performance with a source impedance of 200Ω.

Relatively high input stage current is used to achieve this low noise. This results in relatively high input bias current and input current noise. As a result, the INA103 may not provide best noise performance with source impedances greater than 10kΩ. For source impedance greater than 10kΩ, consider the INA114 (excellent for precise DC applications), or the INA111 FET-input IA for high speed applications.

OFFSET ADJUSTMENT

Offset voltage of the INA103 has two components: input stage offset voltage is produced by A₁ and A₂; and, output stage offset is produced by A₃. Both input and output stage offset are laser trimmed and may not need adjustment in many applications.

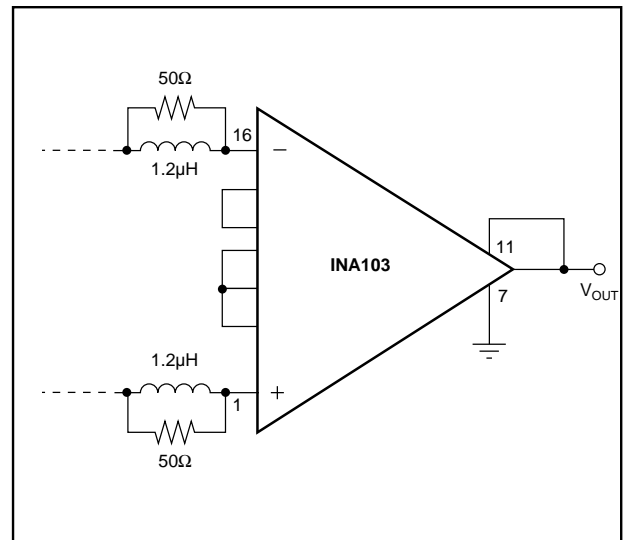

FIGURE 2. Input Stabilization Network.

Offset voltage can be trimmed with the optional circuit shown in Figure 3. This offset trim circuit primarily adjusts the output stage offset, but also has a small effect on input stage offset. For a 1mV adjustment of the output voltage, the input stage offset is adjusted approximately 1µV. Use this adjustment to null the INA103's offset voltage with zero differential input voltage. Do not use this adjustment to null offset produced by a sensor, or offset produced by subsequent stages, since this will increase temperature drift.

To offset the output voltage without affecting drift, use the circuit shown in Figure 4. The voltage applied to pin 7 is summed at the output. The op amp connected as a buffer provides a low impedance at pin 7 to assure good common-mode rejection.

Figure 5 shows a method to trim offset voltage in AC-coupled applications. A nearly constant and equal input bias current of approximately 2.5µA flows into both input terminals. A variable input trim voltage is created by adjusting the balance of the two input bias return resistances through which the input bias currents must flow.

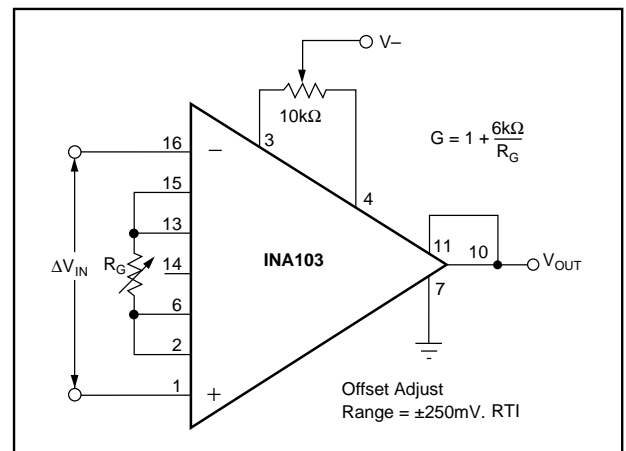

FIGURE 3. Offset Adjustment Circuit.

Figure 6 shows an active control loop that adjusts the output offset voltage to zero. A₂, R, and C form an integrator that produces an offsetting voltage applied to one input of the INA103. This produces a -6dB/octave low frequency roll-off like the capacitor input coupling in Figure 5.

COMMON-MODE INPUT RANGE

For proper operation, the combined differential input signal and common-mode input voltage must not cause the input amplifiers to exceed their output swing limits. The linear input range is shown in the typical performance curve “Maximum Common-Mode Voltage vs Output Voltage.” For a given total gain, the input common-mode range can be increased by reducing the input stage gain and increasing the output stage gain with the circuit shown in Figure 7.

OUTPUT SENSE

An output sense terminal allows greater gain accuracy in driving the load. By connecting the sense connection at the load, I•R voltage loss to the load is included inside the feedback loop. Current drive can be increased by connecting a current booster inside the feedback loop as shown in Figure 11.

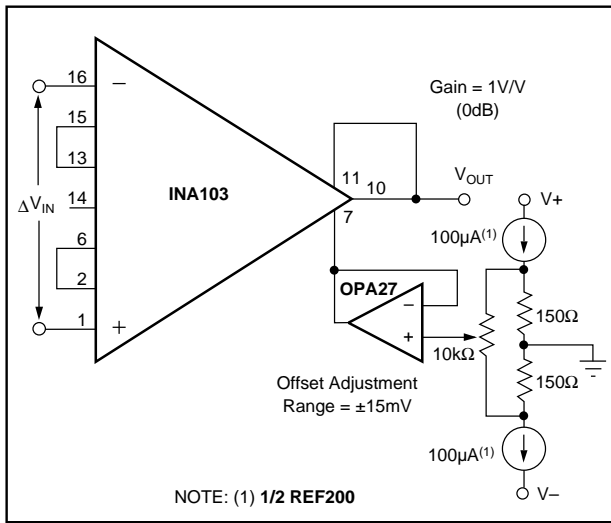

FIGURE 4. Output Offsetting.

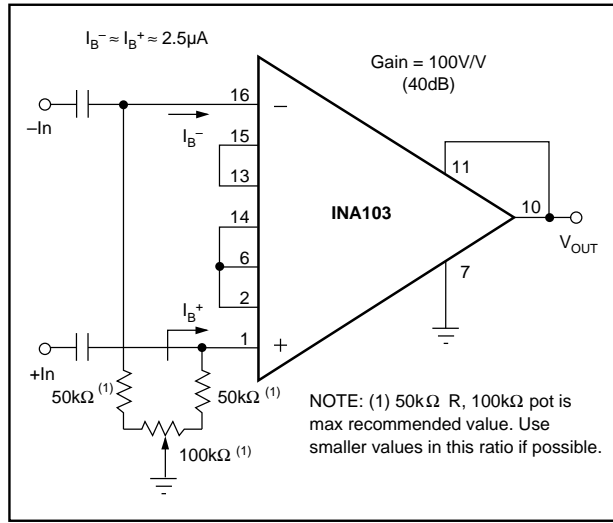

FIGURE 5. Input Offset Adjustment for AC-Coupled Inputs.

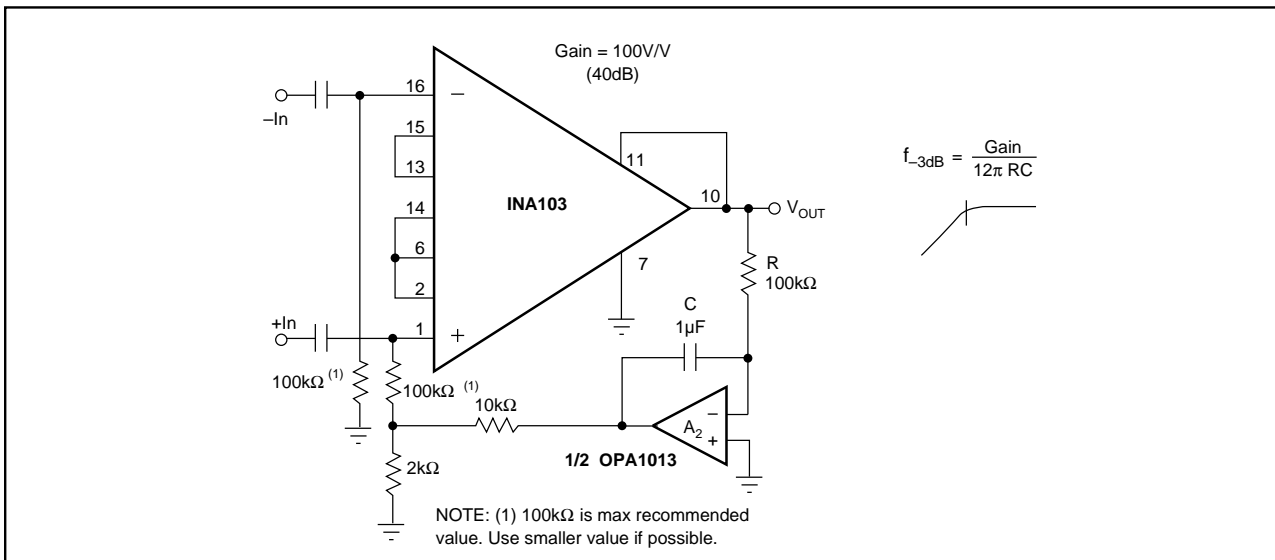

FIGURE 6. Automatic DC Restoration.

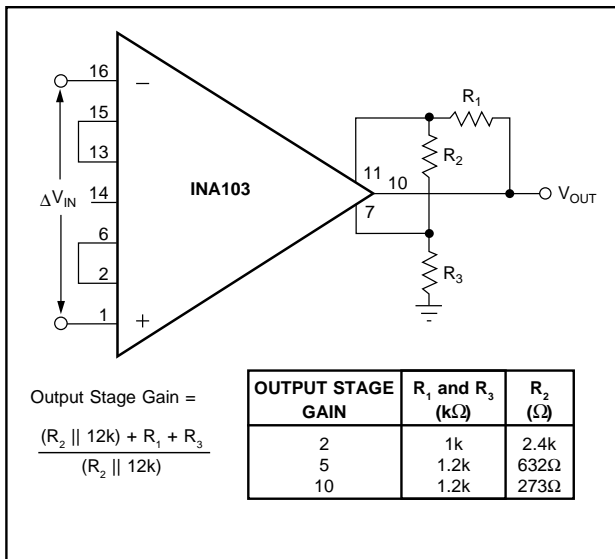

FIGURE 7. Gain Adjustment of Output Stage.

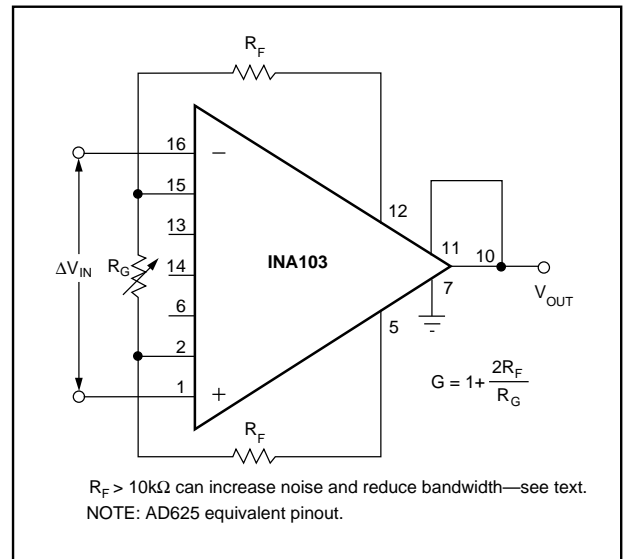

FIGURE 8. Use of External Resistors for Gain Set.

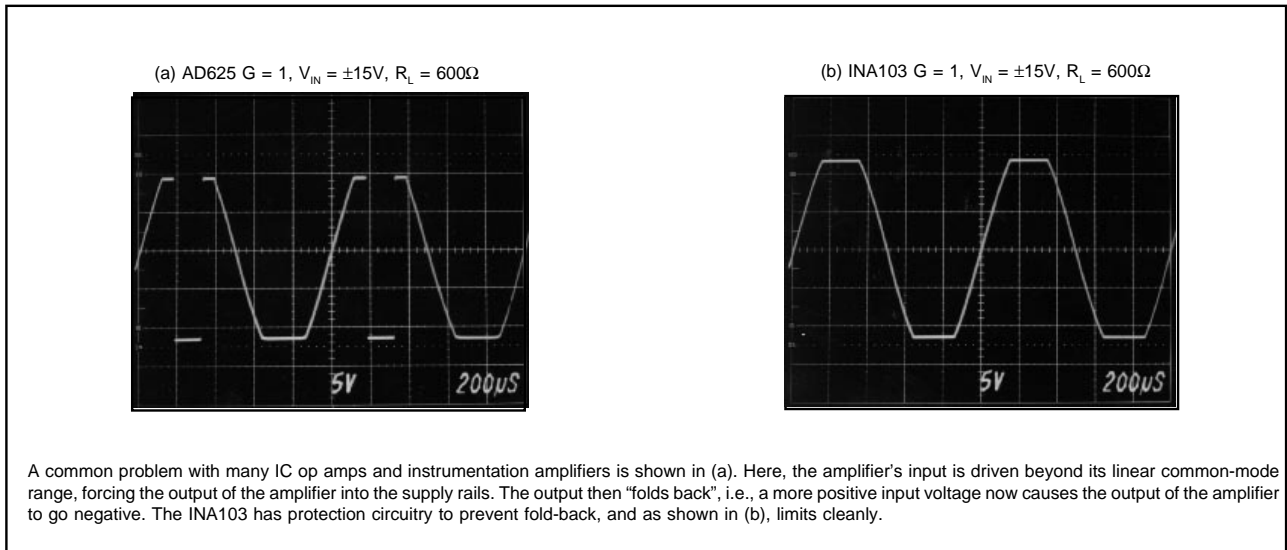

FIGURE 9. INA103 Overload Condition Performance.

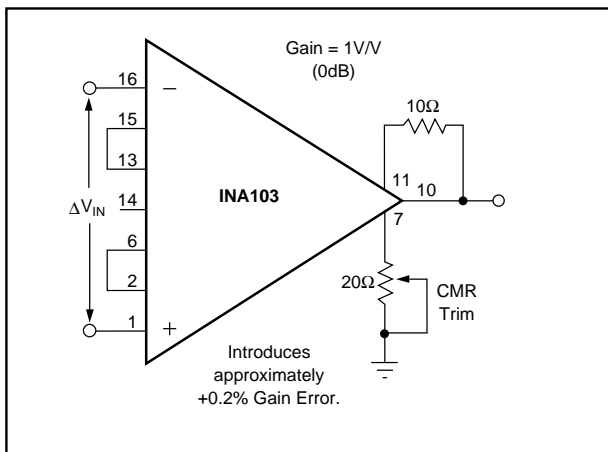

FIGURE 10. Optional Circuit for Externally Trimming CMR.

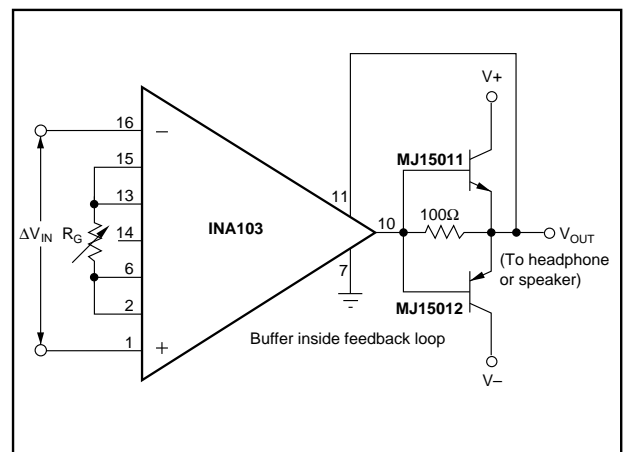

FIGURE 11. Increasing Output Circuit Drive.

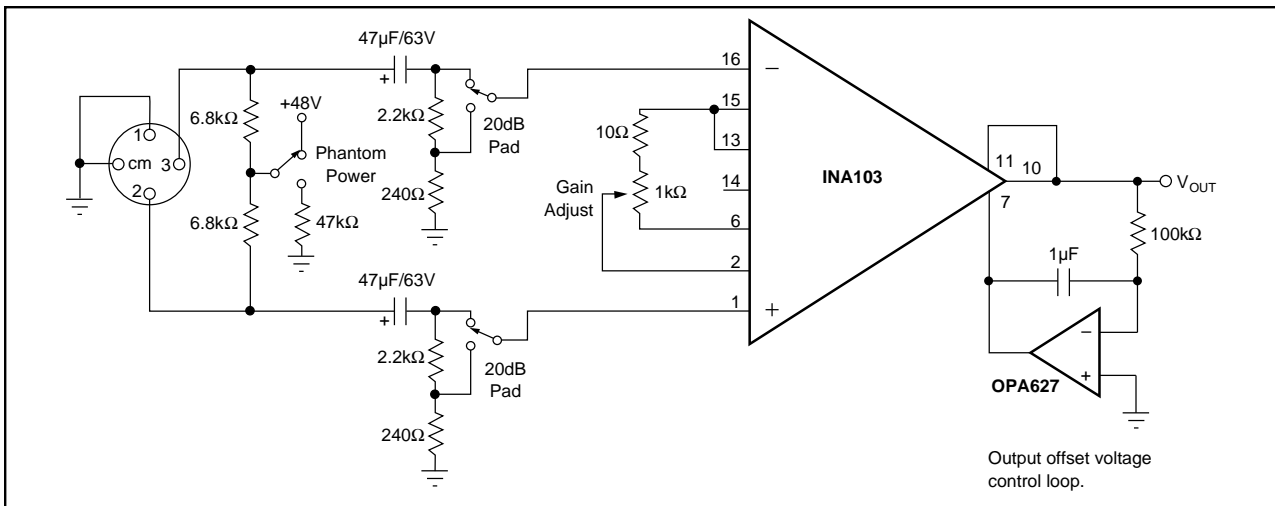

FIGURE 12. Microphone Preamplifier with Provision for Phantom Power Microphones.

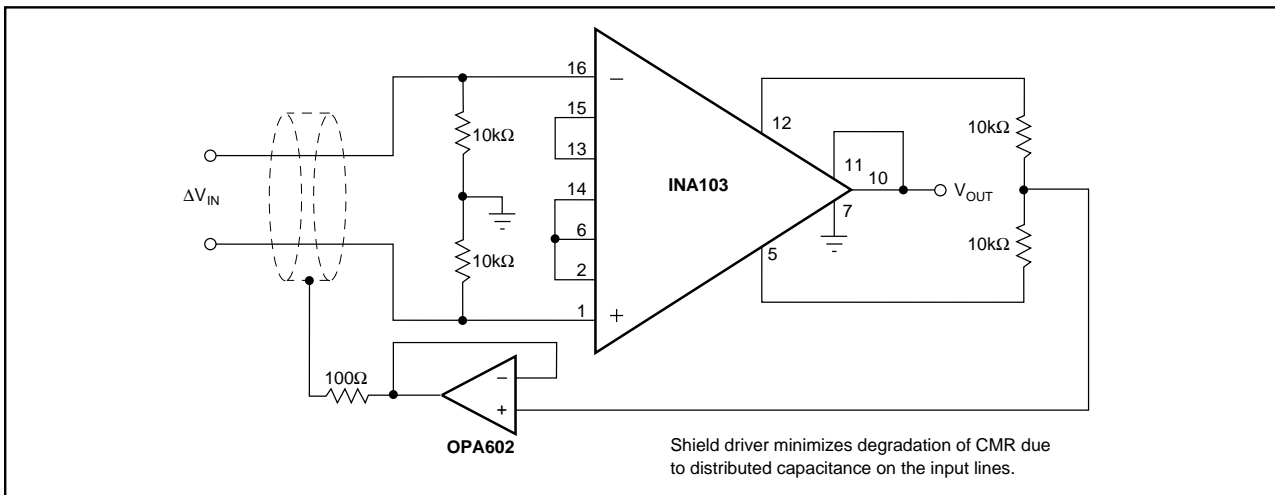

FIGURE 13. Instrumentation Amplifier with Shield Driver.

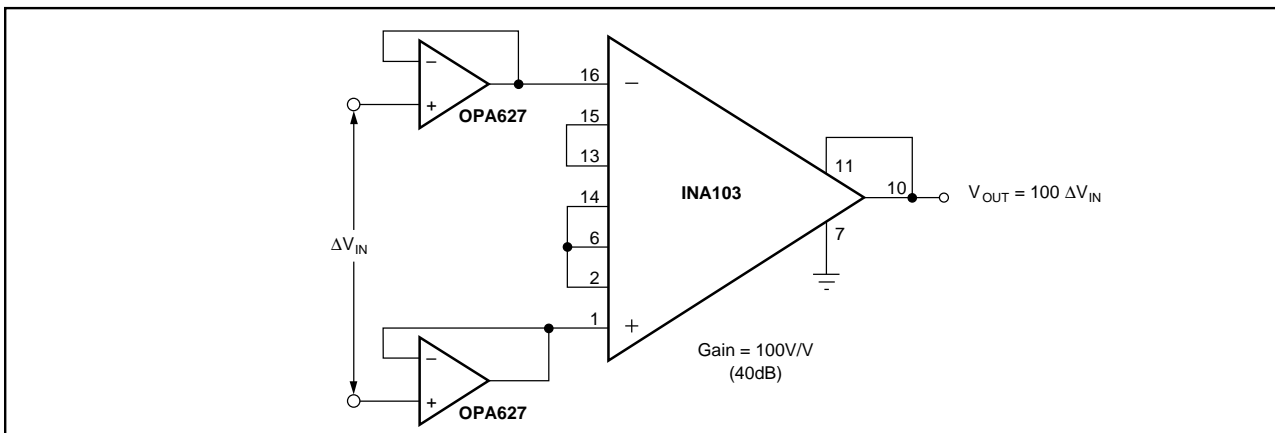

FIGURE 14. Gain-of-100 INA103 with FET Buffers.

The information provided herein is believed to be reliable; however, BURR-BROWN assumes no responsibility for inaccuracies or omissions. BURR-BROWN assumes no responsibility for the use of this information, and all use of such information shall be entirely at the user's own risk. Prices and specifications are subject to change without notice. No patent rights or licenses to any of the circuits described herein are implied or granted to any third party. BURR-BROWN does not authorize or warrant any BURR-BROWN product for use in life support devices and/or systems.